

# THIẾT BỊ ĐỌC BIỂN SỐ PHƯƠNG TIỆN GIAO THÔNG CHUYÊN DỤNG

Tích hợp tính năng nhận diện biển số tự động trên camera sử dụng công nghệ AI...

**MODEL: TB-VEB7-N562VFPI**

**Sản xuất tại Nhà máy E111 - BCA**

## Product Image Dimensions

- ✓ Power supply: DC12V(-15%~+25%)/POE (IEEE 802.3af)
- ✓ Dimensions:  $\phi$  110 × 356 mm
- ✓ Working temperature: -40°C ~ 55°C (-40°F ~ 131°F)

## Features

- ✓ 1/1.8" progressive scan CMOS
- ✓ 50fps/60fps@5MP(2880×1620)
- ✓ P-iris Motorized lens
- ✓ Intelligent AI-powered LPR Algorithm
- ✓ Max recognition speed of 120km/h
- ✓ True WDR, 3D DNR, ROI, HLC, BLC
- ✓ DC12V/PoE power supply
- ✓ IP67, IK10

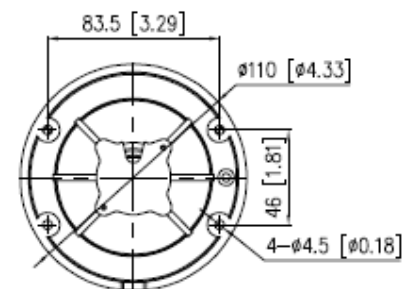
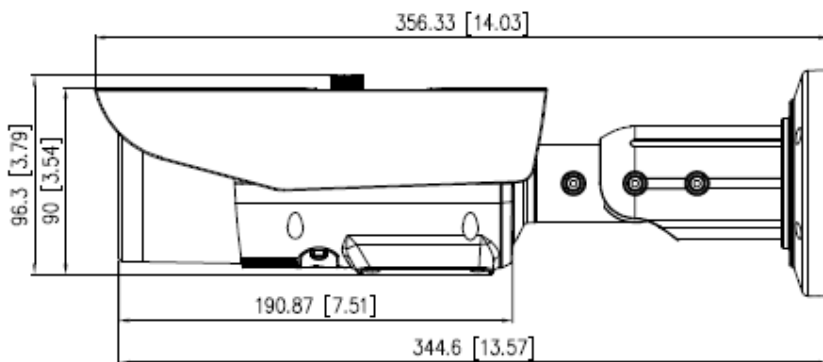

**E111 FACTORY – THANH BINH BCA CO., LTD.**

Industrial Zone – Lai Yen – Hoai Duc – Ha Noi

Tel: 1800-282229 | Email : [info@tbvision.com.vn](mailto:info@tbvision.com.vn) | Website : [tbvision.com.vn](http://tbvision.com.vn) |



## Specifications

Camera		
Image Sensor	1/2.8" Progressive Scan CMOS	
Max. Resolution	2880×1620	
Electronic Shutter	Auto/Manual, 1/5s ~ 1/100,000s	
Min. illumination	Color: 0.0025 Lux @ (F1.2, AGC ON) B/W: 0 Lux with IR on	
S/N Ratio	55 dB	
Wide Dynamic Range	True WDR	
Angle Adjustment	Pan: 0°~360°, Tilt: 0°~90°, Rotation: 0°~360°	
Lens		
Focal Length	Motorized lens	
Iris	P-iris	
Focal Length	4.1 to 12.8mm	8 to 32mm
F Number	F1.53 to F3.3	F1.6
Angle of View	H: 105° ~ 32°, V: 76° ~ 24°	H: 42° ~ 15°, V: 23° ~ 8°
Focus Control	Motorized	
Illuminator		
Supplement Light	IR LED Light	
Light Control	Auto/Manual	
Illumination Distance	Up to 50m	Up to 80m
Video		
Streaming Capability	3 Streams	
Stream/Frame Rate	Stream1: 2592×1520, 2304×1296, 1920×1080, 1280×720 @ 50/60fps Stream2: D1, VGA, CIF @25/30fps Stream3: VGA, CIF, QVGA @25/30fps	
Bit Rate Control	CBR/VBR	
Bit Rate	Stream1: 500kbps~16Mbps Stream2: 500kbps~12Mbps Stream3: 200kbps~12Mbps	
Smart Encoder	Support	
ROI	Up to 8 areas	
Image		
Image Adjustment	Brightness, Sharpness, Contrast, Saturation adjustable	
Mirror	Support	
White Balance	Auto/Manual	
Day/Night Setting	Auto, Day, Night, Time	
Smart Illumination	Support	
Noise Reduction	2D/3D DNR	
Image Enhancement	HLC, BLC, Defog, Anti-shake	
Privacy Masking	Up to 4 areas	



**E111 FACTORY – THANH BINH BCA CO., LTD.**

Industrial Zone – Lai Yen – Hoai Duc – Ha Noi

Tel: 1800-282229 | Email : [info@tbvision.com.vn](mailto:info@tbvision.com.vn) | Website : [tbvision.com.vn](http://tbvision.com.vn) |



Audio	
Audio Compression	G.711, RAW_PCM
Bit Rate	8kbps, 16kps, 64kbps
Network	
Protocols	IPv4/IPv6, 802.1x, HTTP, HTTPS, TCP/UDP, RTSP, DHCP, NTP, RTCP/RTP, PPPoE, SMTP, DNS, FTP, ARP, SNMP
Interoperability	ONVIF, SDK, CGI
Streaming Method	Multicast
Max. User Access	10 Users
Web Viewer	<IE11, Chrome, Firefox
Language	English, Chinese, Polish, Italian, Portuguese, Spanish, Russian, French, Czech, Hungarian. Default: English
LPR	
Vehicle Speed	Up to 120km/h
Country Region Supported	Americas and Europe
Attributes Identification	Vehicle type, vehicle color and license plate
White/Black List	Up to 5000 records
LPR Smart Search	Support
Interface	
Network Interface	1 Ethernet (10/100 Base-T) RJ-45 Connector
Audio Interface	1ch Input, 1ch Output
Alarm Interface	1ch Input, 2ch Output
RS485	Support
Wiegand	Support
Reset Button	Support
SD Card Slot	Built-in, up to 256GB
Electrical	
Power Supply	DC12V (-15%~+20%)/POE (IEEE 802.3af)
Power Consumption	Max 12 W
Operating Temperature	-40°C ~ 60°C (-40°F ~ 140°F)
Operating Humidity	Less than 90% RH
Ingress Protection	IP67, IK10
Certifications	CE/FCC
Casing	Metal
Dimensions	φ 110 × 356 mm
Net Weight	1.5 Kg



**E111 FACTORY – THANH BINH BCA CO., LTD.**

Industrial Zone – Lai Yen – Hoai Duc – Ha Noi

Tel: 1800-282229 | Email : [info@tbvision.com.vn](mailto:info@tbvision.com.vn) | Website : [tbvision.com.vn](http://tbvision.com.vn) |

